

SBK-Heating manifold 3000

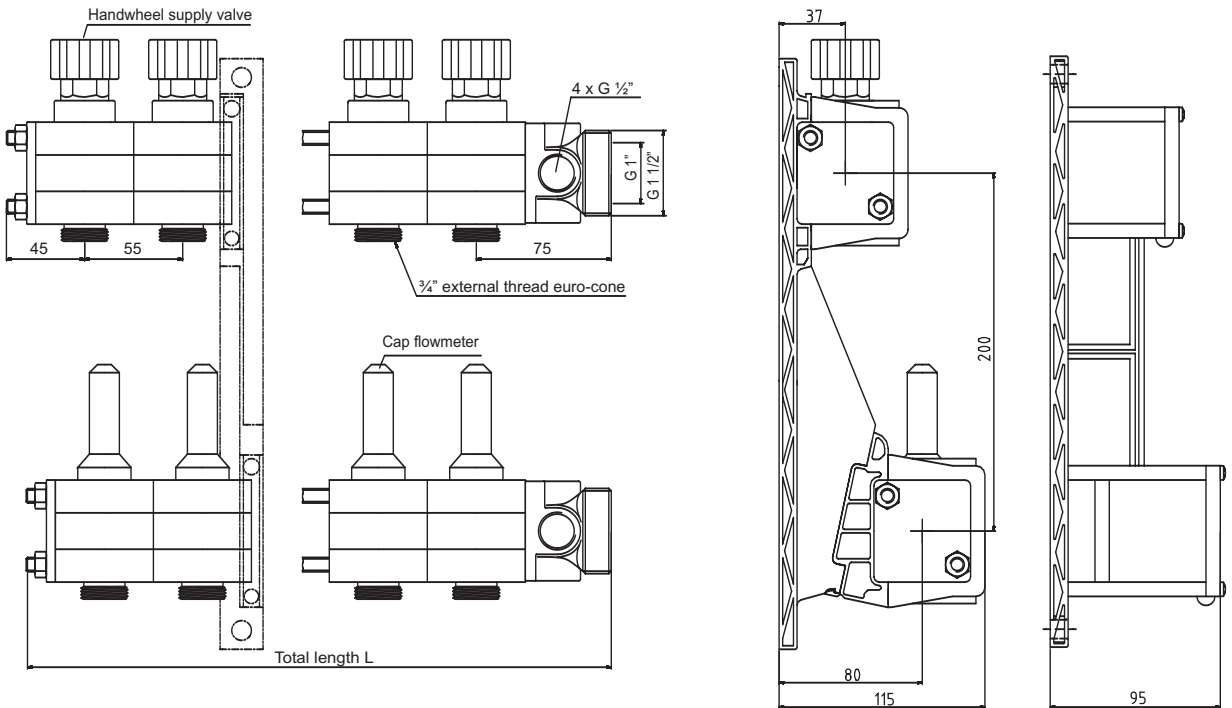

Number of circuits	2	3	4	5	6	7	8	9	10	11	12	13	14	15	16	17
Total length L (mm)	175	230	285	340	395	450	505	560	615	670	725	780	835	890	945	1000
Length of threaded bars (mm)	135	190	245	300	355	410	465	520	575	630	685	740	795	850	905	960

Application area:

Suitable for water, water glycol mixture up to 30% concentration.

Request written release of the manufacturer, if rust-proofing or anti-freezing agents, acids or leaches or other additives are used.

Not suitable for areas where ammonia or ammoniacal compounds occur.

No direct solar radiation in outside areas! Protect against UV-radiation!

Installation only in dry environment, if operating or ambient temperatures are below freezing point.

max. test pressure:

10 bar. Execute pressure test only with water!

max. positive operating pressure:

6 bar

Operating temperatures:

-20°C to +90°C

Rinse and fill:

The manifold may be rinsed and filled only in flow direction.

Material:

Case made of plastic, brass parts made of CuZn40Pb2, gaskets made of EPDM

Tightening torques:

Nuts M8: 4 Nm
 Supply valve: 8 Nm
 Flowmeter: 8 Nm

The manifold installation: (see page 6)

SBK-Heating manifold 3000

Miscellaneous:

Use screw connections which make an easy exchange of the manifold possible.

Close not connected manifold circuits with plugs or caps. Additionally the valve of the supply and the flowmeter of the return module have to be closed completely.

The connected pipes at the manifold circuit may not exert permanent tensile or pressure load on the manifold.

The manifold circuits are rotatable 180° against each other.

They can be adapted on different pipe distances by spacers.

SBK-Heating manifold 3000 - Flow characteristic

Flow characteristic

determined at 5th circuit

Supply max. open

Return preset

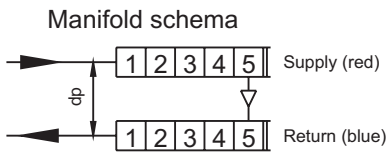

Example:

Pump pressure and pressure drop respectively 0,15bar
 Desired flow 250 l/h
 Open valve maximal, then
 4 turns to the right

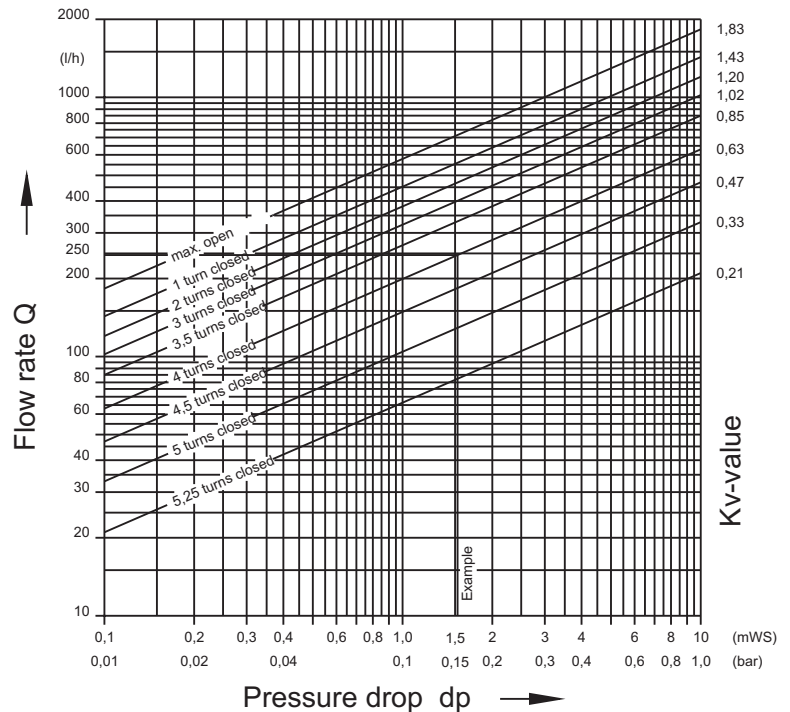

SBK Supply valve

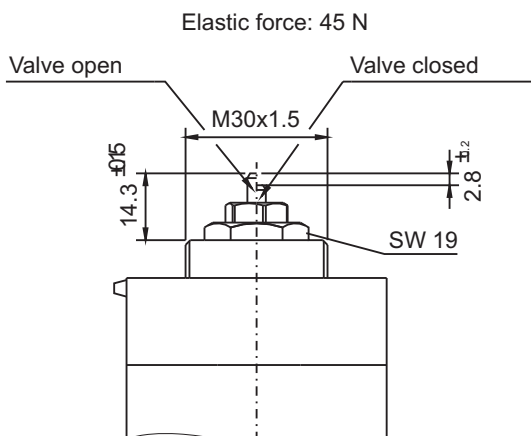

SBK-Heating manifold 3000 - Flowmeter

If the German Construction Contract Procedures for orders are agreed, each specialized craftsman is legally obligated not only to make the hydraulic balancing during the installation of floor heatings but also to prove it (VOB, part C, DIN 18380-heating systems).

It's also state-of-the-art to balance heating systems hydraulically. Furthermore the hydraulic balancing is physically mandatory, because water searches the line of the least resistance.

The hydraulic balancing:

The individual circuits of a floor heating have to be coordinated and adjusted in that way, that each circuit receives only the volume flow which is necessary for the respective heating output.

The required volume flow can be easily and quickly adjusted by the standard integrated flowmeter of the SBK Heating manifold 3000.

Procedure:

Heating system has to be completely filled and deaerated, operating pressure has to be existent!

- Close all flowmeters of the return manifold, open all valves of the supply manifold.
- Adjust volume flow of the first circuit by turning the transparent plastic pipe according to the heat requirement calculation (use handwheel of the supply valve).
- Indicator pin of the plastic pipe rises upward.
- Turn plastic pipe as far as the indicator pin indicates the desired value.
- Balance next circuit as aforementioned.
- Because of the interaction of the circuits, it possibly will be necessary to make corrections in a second pass.

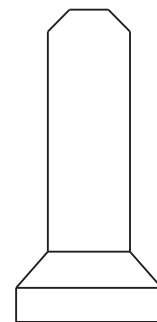
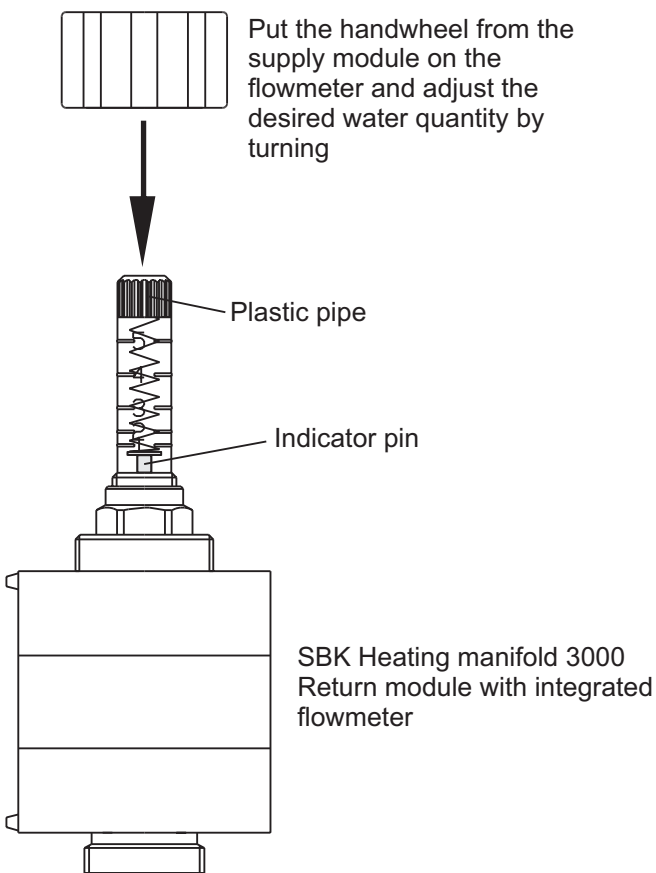

Cap
Return module

Protect hydraulic balancing against unauthorized adjusting

Close flowmeter with cap and provide it with a lead seal.

Flowmeters with different indicating ranges are available for different flow rates

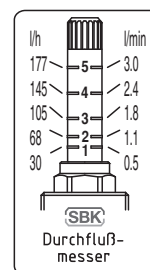

Indicator pin green

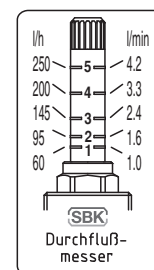

Indicator pin red

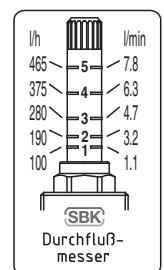

Indicator pin yellow