

## SBK -Multipurpose manifold 5000 KST 1 1/4"

End plate optional:  
 -without internal thread  
 -with 1/2" internal thread  
 -3/4" internal thread  
 -1" internal thread

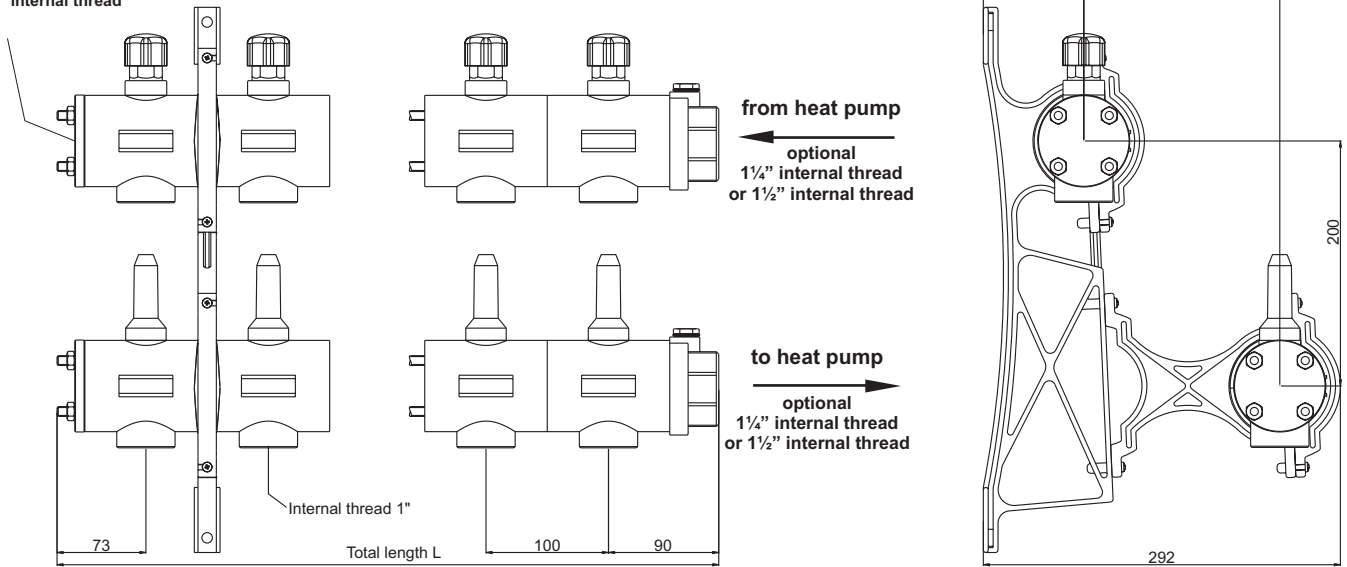

Number of circuits	2	3	4	5	6	7	8	9	10
Total length L (mm)	263	363	463	563	663	763	863	963	1063
Length of threaded bars (mm)	230	330	430	530	630	730	830	930	1030

## SBK -Multipurpose manifold 5000 KST 1 1/4" - Flow characteristic

### Measuring section:

Inflow = G1 1/2", Outflow = G1 1/2",

Connection between supply and return manifold: straight pipe sections G1", ca. 100 mm long

Valves of the supply and flowmeters of the return max. open

Medium water 18 °C

Flow rate  $Q_{max} = 13.950$  l/h by  $dp = 1$  bar

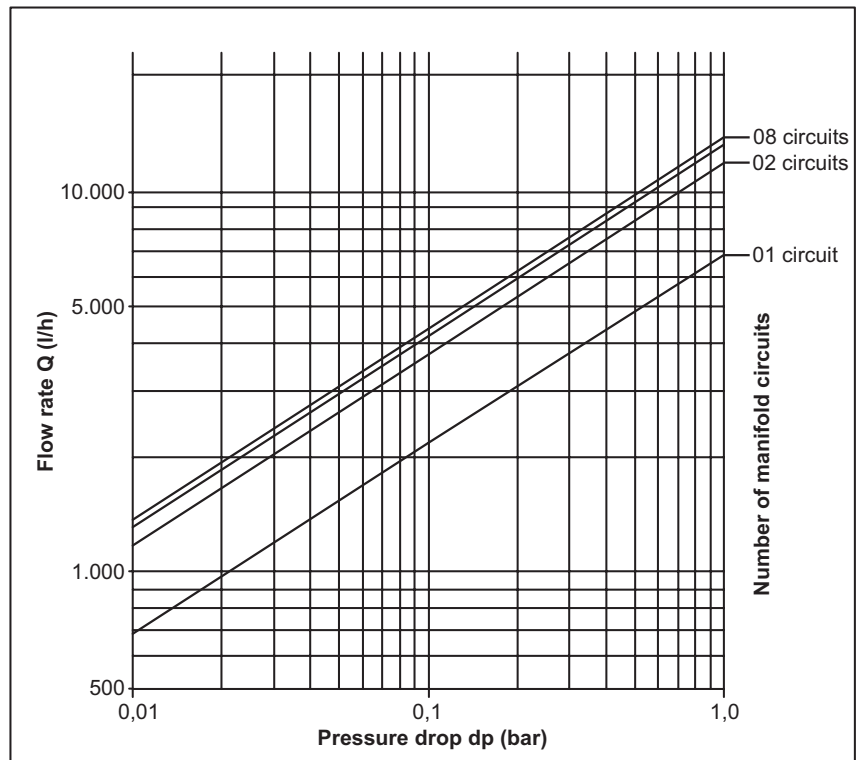
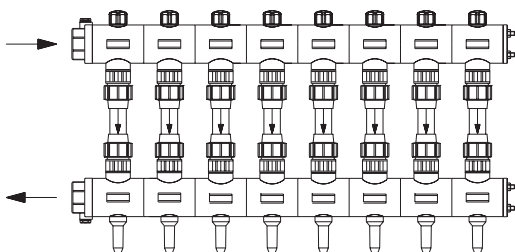

## SBK -Multipurpose manifold 5000 KST 2"

End plate optional:  
 -without internal thread  
 -with 1/2" internal thread  
 -3/4" internal thread  
 -1" internal thread

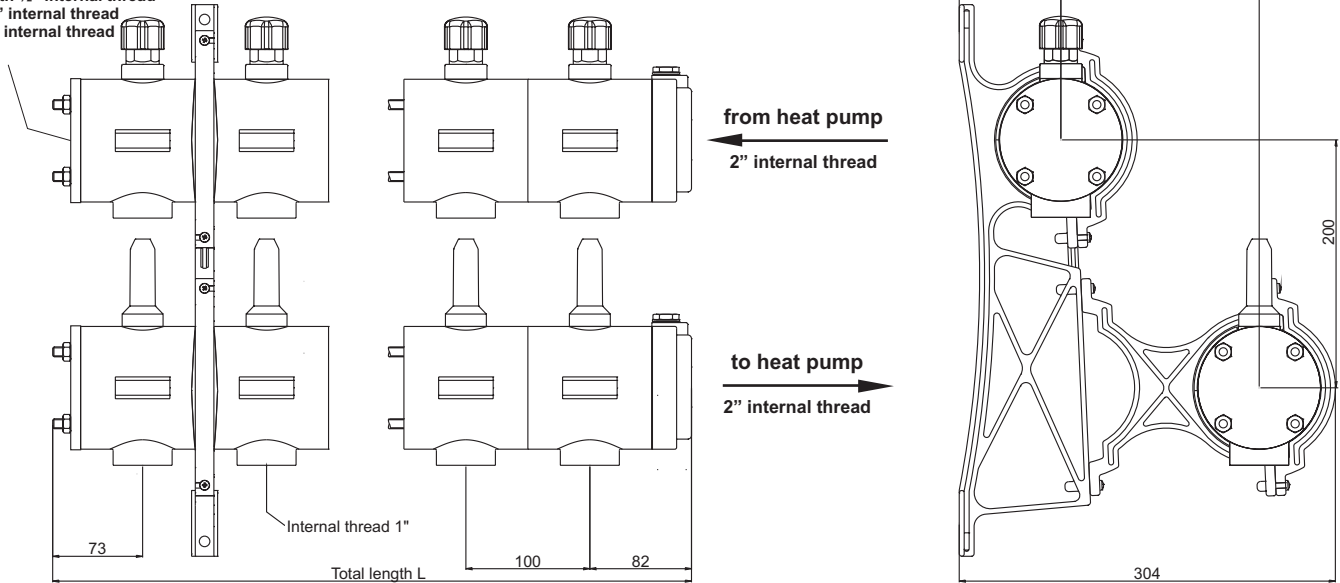

Number of circuits	2	3	4	5	6	7	8	9	10
Total length L (mm)	255	355	455	555	655	755	855	955	1055
Length of threaded bars (mm)	230	330	430	530	630	730	830	930	1030

## SBK -Multipurpose manifold 5000 KST 2"- Flow characteristic

### Measuring section:

Inflow = G2", Outflow = G2",

Connection between supply and return manifold: straight pipe sections G1", ca. 100 mm long

Valves of the supply and flowmeters of the return max. open

Medium water 18 °C

Flow rate  $Q_{max} = 36.080$  l/h by  $dp = 1$  bar

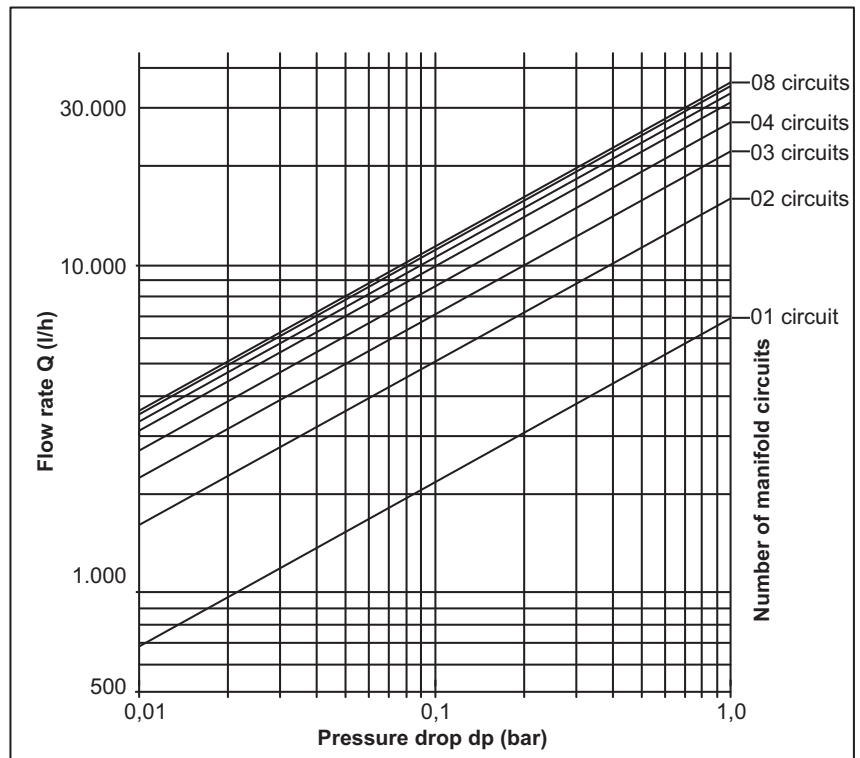
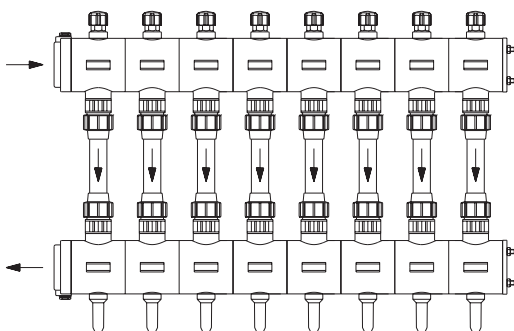

## **SBK** -Multipurpose manifold 5000 manifold installation

**Pay attention on cleanness during the manifold installation. The gaskets may not encounter oil or lubrication grease.**

1. Cut threaded bars to lengths and screw them into connection block.
2. Apply connection block with threaded bars vertical to a fixed base.
3. First put off one flat gasket and then the manifold module.
4. Put off one flat gasket once again after the last manifold module.
5. Put on the end plate.
6. Tighten the nuts until modules lie together (torque 8 Nm).

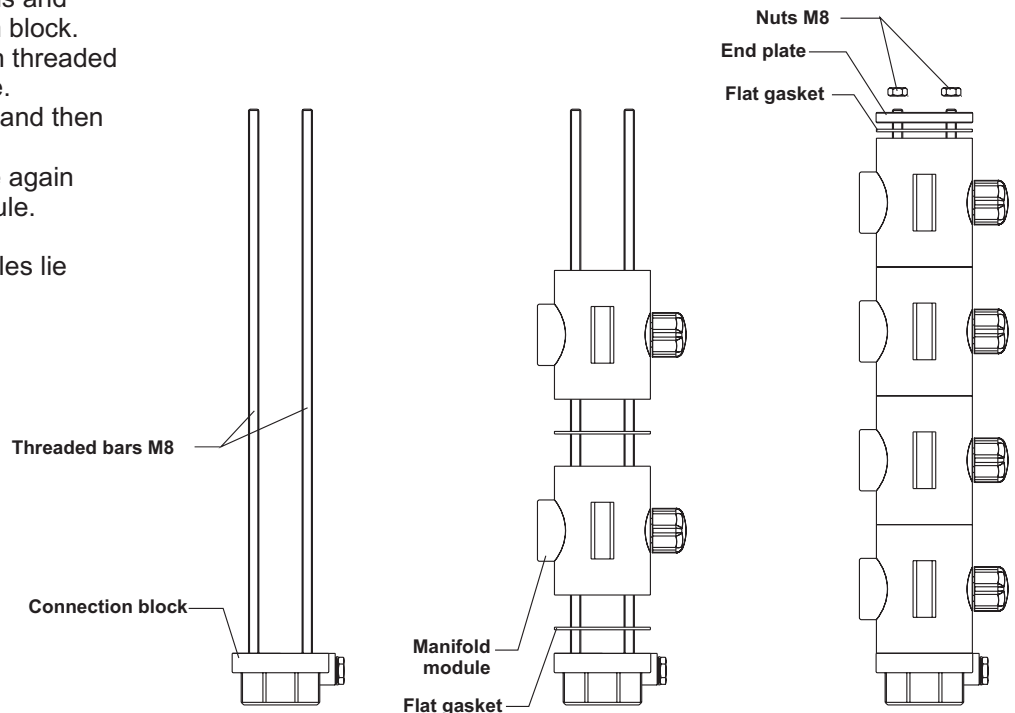

### **Application area:**

Released for water & water glycol mixtures as per manufacturer's instructions.

(TYFOCOR L®, TYFOCOR®, TYFO-Spezial®)

Request written release of the manufacturer, if rust-proofing or anti-freezing agents, acids or leaches or other additives are used.

Conditionally suitable for areas where ammonia or ammoniacal compounds occur.

No direct solar radiation in outside areas! Protect against UV-radiation!

Installation only in dry environment, if operating or ambient temperatures are below freezing point.

Only screw connections made of plastic are permitted as circuit screw connections. We recommend Pipe Sealing Cord Loctite® 55™. Notice the Product information.

### **max. test pressure:**

10 bar. Execute pressure test only with water!

### **max. positive operating pressure:**

6 bar

### **Operating temperatures:**

-20°C to +70°C

### **Rinse and fill:**

The manifold may be rinsed and filled only in flow direction.

### **Material:**

Case made of plastic, brass parts made of CuZn40Pb2, gaskets made of EPDM

### **Tightening torques:**

Supply valve/Flowmeter: 20 Nm

Nuts M8: 8 Nm

Plastic screw connections: 18 Nm

### **Miscellaneous:**

Use screw connections which make an easy exchange of the manifold possible.

Close not connected manifold circuits with plugs or caps. Additionally the valve of the supply module and the flowmeter of the return module have to be closed completely.

The connected pipes at the manifold circuit may not exert permanent tensile or pressure load on the manifold. The manifold circuits are rotatable 180° against each other.

They can be adapted on different pipe distances by spacers.

## **SBK** -Multipurpose manifold 5000 KST - Flowmeter

### **The hydraulic balancing:**

The individual circuits can be coordinated and adjusted in that way, that each circuit receives only the volume flow which is necessary for the respective heat or refrigeration capacity.

The desired volume flow can be easily and quickly adjusted by the standard integrated flowmeter of the SBK Multipurpose manifold.

### **Procedure:**

**System has to be completely filled and deaerated, operating pressure has to be existent!**

- Close all flowmeters of the return manifold, open all valves of the supply manifold.
- Adjust volume flow of the first circuit by turning the transparent plastic pipe according to the heat requirement calculation (use handwheel of the supply valve).
- Indicator pin of the plastic pipe rises upward.
- Turn plastic pipe as far as the indicator pin indicates the desired value.
- Balance next circuit as aforementioned.
- Because of the interaction of the circuits, it possibly will be necessary to make corrections in a second pass.

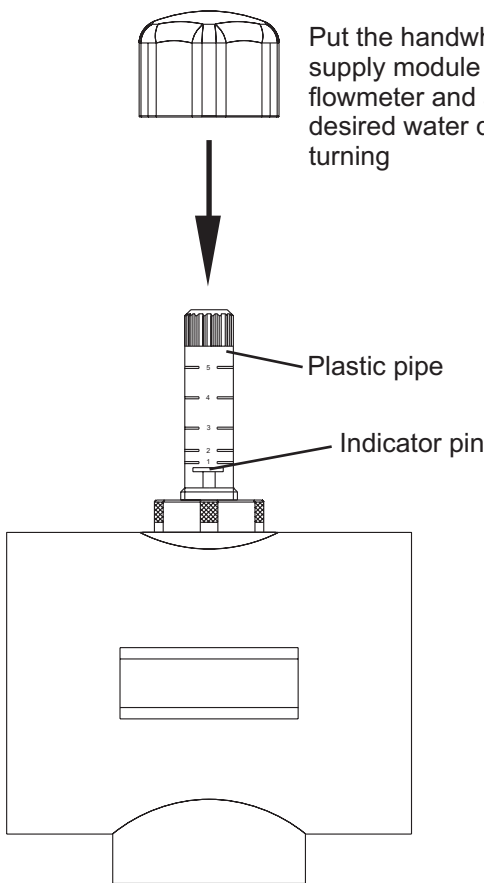

SBK Multipurpose manifold 5000  
Return module with integrated  
flowmeter

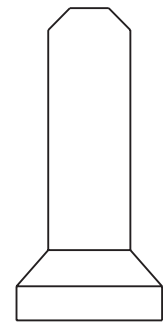

Cap  
Return module

**Protect hydraulic  
balancing against  
unauthorized adjusting**

Close flowmeter with cap  
and provide it with a lead  
seal.

**Flowmeters with different indicating ranges are available for different flow rates**

<b>Indicator pin</b>	<b>Black</b>	<b>Yellow</b>	<b>Red</b>	<b>Green</b>
Marking 1	500l/h	200l/h	100l/h	50l/h
Marking 2	800l/h	400l/h	250l/h	100l/h
Marking 3	1.100l/h	550l/h	350l/h	150l/h
Marking 4	1.400l/h	700l/h	450l/h	200l/h
Marking 5	1.780l/h	1050l/h	600l/h	250l/h

**Values apply to medium water, 20°C**